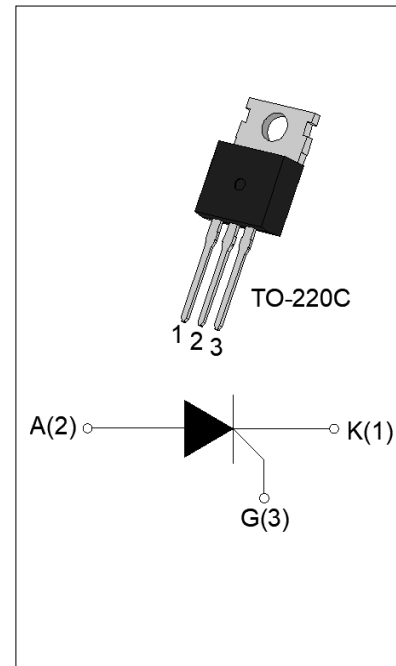


DESCRIPTION:

With high ability to withstand the shock loading of large current, SCT1208C provides high dV/dt rate with strong resistance to electromagnetic interference. It is especially recommended for use on hair straightener, motorcycle voltage regulator etc. Package TO-220C is RoHS compliant.

MAIN FEATURES

| Symbol | Value | Unit |
|-------------------|-----------|------|
| $I_{T(RMS)}$ | 8 | A |
| V_{DRM}/V_{RRM} | 1200 | V |
| I_{GT} | ≤ 15 | mA |



ABSOLUTE MAXIMUM RATINGS

| Parameter | Symbol | Value | Unit |
|--|--------------|---------|-------------|
| Storage junction temperature range | T_{stg} | -40-150 | $^{\circ}C$ |
| Operating junction temperature range | T_j | -40-125 | $^{\circ}C$ |
| Repetitive peak off-state voltage ($T_j=25^{\circ}C$) | V_{DRM} | 1200 | V |
| Repetitive peak reverse voltage ($T_j=25^{\circ}C$) | V_{RRM} | 1200 | V |
| Average on-state current ($T_c \leq 103^{\circ}C$) | $I_{T(AV)}$ | 5 | A |
| RMS on-state current ($T_c \leq 103^{\circ}C$) | $I_{T(RMS)}$ | 8 | A |
| Non repetitive surge peak on-state current ($t_p=10ms, T_j=25^{\circ}C$) | I_{TSM} | 85 | A |
| Non repetitive surge peak on-state current ($t_p=8.3ms, T_j=25^{\circ}C$) | | 94 | |
| I^2t value for fusing ($t_p=10ms, T_j=25^{\circ}C$) | I^2t | 36 | A^2s |
| Critical rate of rise of on-state current ($I_G=2 \times I_{GT}, f=100Hz, T_j=125^{\circ}C$) | di/dt | 100 | $A/\mu s$ |
| Peak gate current ($t_p=20\mu s, T_j=125^{\circ}C$) | I_{GM} | 4 | A |
| Average gate power dissipation ($T_j=125^{\circ}C$) | $P_{G(AV)}$ | 1 | W |

| | | | |
|--|----------|---|----|
| Peak gate power | P_{GM} | 5 | W |
| Peak pulse voltage ($T_j=25^\circ\text{C}$; non-repetitive, off-state; FIG.7) | V_{pp} | 1 | kV |

ELECTRICAL CHARACTERISTICS ($T_j=25^\circ\text{C}$ unless otherwise specified)

| Symbol | Test Condition | Value | | | Unit |
|-----------|--|-------|------|------|------------------|
| | | MIN. | TYP. | MAX. | |
| I_{GT} | $V_D=12\text{V } R_L=33\Omega$ | - | - | 15 | mA |
| V_{GT} | | - | - | 1 | V |
| V_{GD} | $V_D=V_{DRM} T_j=125^\circ\text{C } R_L=3.3\text{k}\Omega$ | 0.2 | - | - | V |
| I_L | $I_G=1.2I_{GT}$ | - | - | 40 | mA |
| I_H | $I_T=500\text{mA}$ | - | - | 30 | mA |
| dV/dt | $V_D=800\text{V}$ Gate Open $T_j=125^\circ\text{C}$ | 1000 | - | - | V/ μs |
| t_{on} | $I_G=20\text{mA } I_A=200\text{mA } I_R=20\text{mA}$ $T_j=25^\circ\text{C}$ | - | 5 | - | μs |
| t_{off} | | - | 100 | - | μs |

STATIC CHARACTERISTICS

| Symbol | Parameter | | Value(MAX.) | Unit |
|-----------|---|-------------------------|-------------|---------------|
| V_{TM} | $I_{TM}=16\text{A } t_p=380\mu\text{s}$ | $T_j=25^\circ\text{C}$ | 1.6 | V |
| V_{TO} | Threshold voltage | $T_j=125^\circ\text{C}$ | 0.8 | V |
| R_D | Dynamic resistance | $T_j=125^\circ\text{C}$ | 28 | m Ω |
| I_{DRM} | $V_D=V_{DRM} V_R=V_{RRM}$ | $T_j=25^\circ\text{C}$ | 10 | μA |
| I_{RRM} | | $T_j=125^\circ\text{C}$ | 1 | mA |

THERMAL RESISTANCES

| Symbol | Parameter | Value | Unit |
|---------------|--------------------------|-------|---------------------------|
| $R_{th(j-c)}$ | junction to case (DC) | 1.9 | $^\circ\text{C}/\text{W}$ |
| $R_{th(j-a)}$ | junction to ambient (DC) | 45 | $^\circ\text{C}/\text{W}$ |

ORDERING INFORMATION

| | | | | |
|------------------------------|------------------------------|---|---|-----------------------------------|
| <p>S</p> <p>SURGE</p> | <p>CT</p> <p>SCRs</p> | <p>12</p> <p>12: $V_{DRM} / V_{RRM} \geq 1200V$</p> | <p>08</p> <p>$I_{T(RMS)}: 8A$</p> | <p>C</p> <p>C: TO-220C</p> |
|------------------------------|------------------------------|---|---|-----------------------------------|

MARKING

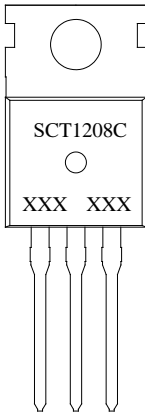
| | |
|---|--|
|  | <p>XXX XXX</p> <p>Year ———— Month ————</p> <p>Production Code</p> |
|---|--|

FIG.1: Maximum power dissipation versus RMS on-state current

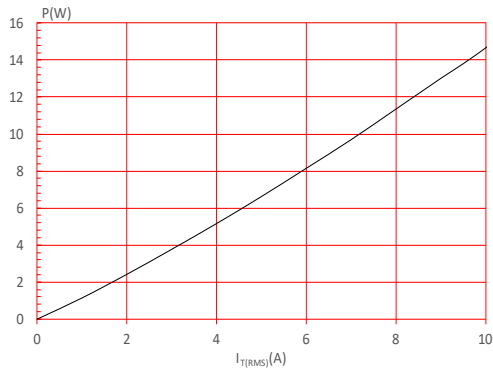


FIG.2: RMS on-state current versus case temperature

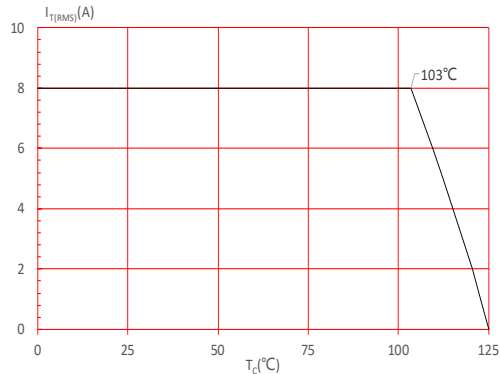


FIG.3: Surge peak on-state current versus number of cycles

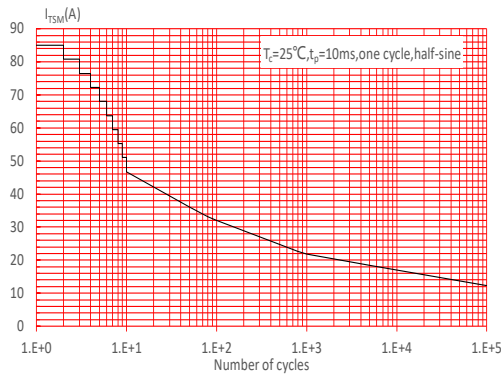


FIG.4: On-state characteristics

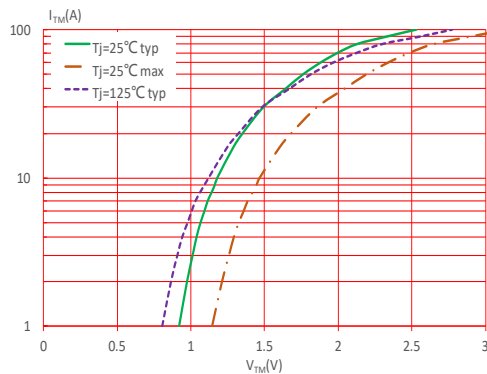


FIG.5: Non-repetitive surge peak on-state current for a sinusoidal pulse with width $t_p < 10\text{ms}$, and corresponding value of I^2t ($di/dt < 100\text{A}/\mu\text{s}$)

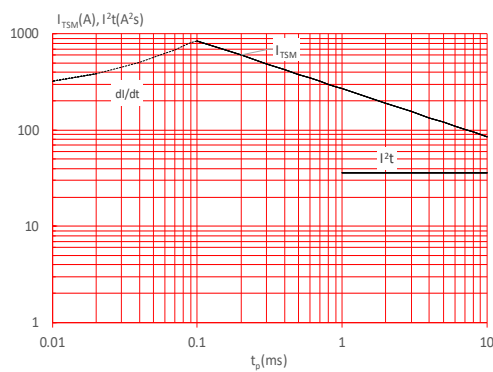


FIG.6: Relative variations of gate trigger current, holding current and latching current versus junction temperature

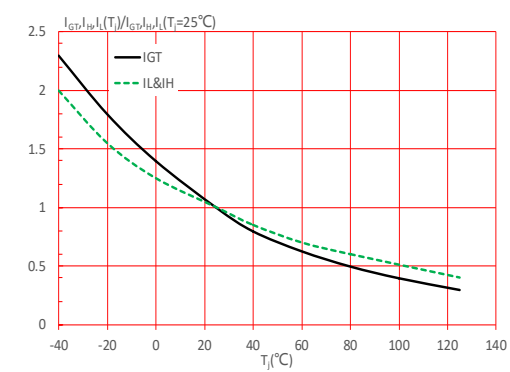
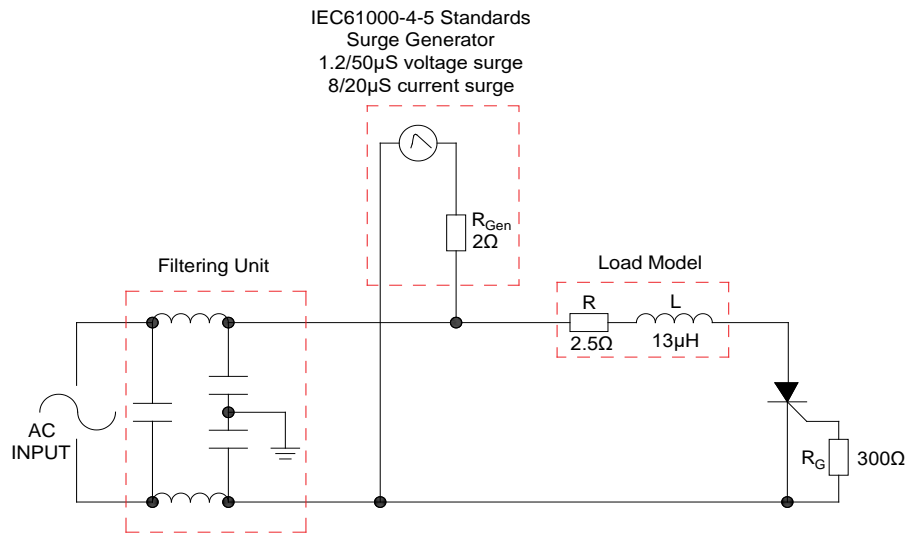


FIG.7: Test circuit for inductive and resistive loads to IEC-61000-4-5 standards.



LEAD FORMING AND SOLDERING

Refer to the application note "Assembly Instructions for Thyristors in Through-hole Package"

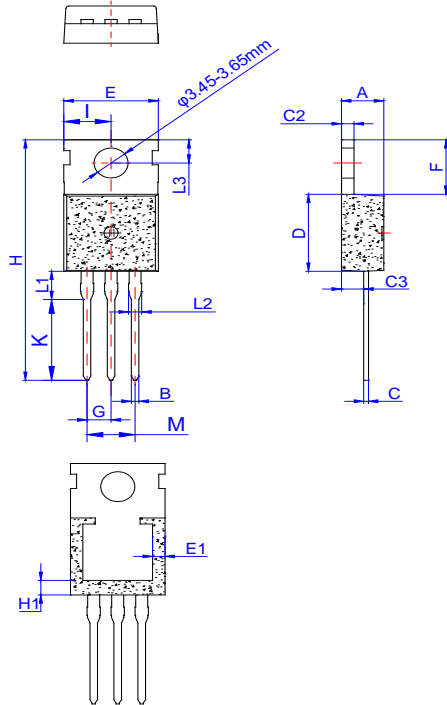
ORDERING INFORMATION

| Order code | Voltage V_{DRM}/V_{RRM} (V) | IGT(mA) | Package | Base qty. (pcs) | Delivery mode |
|------------|----------------------------------|---------|---------|--------------------|------------------|
| SCT1208C | 1200 | 15 | TO-220C | 50 | Tube |

Document Revision History

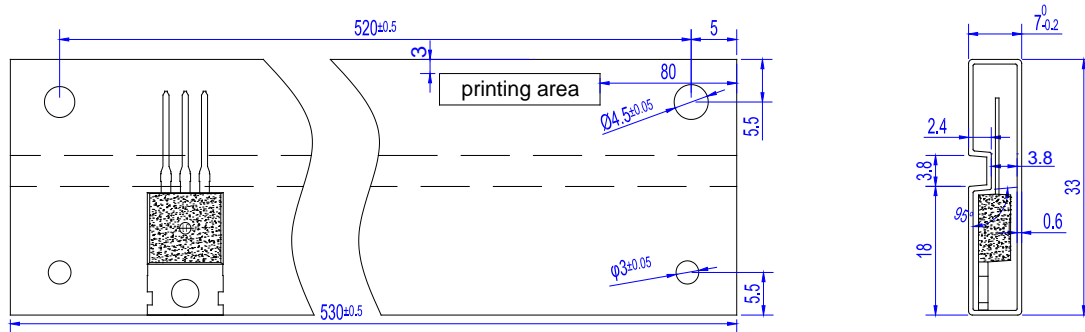
| Date | Revision | Changes |
|--------------|----------|--------------------------------|
| Apr.13, 2023 | A.1.0 | Last update |
| Oct.14, 2025 | A.1.1 | Revise PACKAGE MECHANICAL DATA |

PACKAGE MECHANICAL DATA



| Ref. | Dimensions | | | | | |
|------|-------------|------|-------|--------|------|-------|
| | Millimeters | | | Inches | | |
| | Min. | Typ. | Max. | Min. | Typ. | Max. |
| A | 4.40 | | 4.60 | 0.173 | | 0.181 |
| B | 0.70 | | 0.90 | 0.028 | | 0.035 |
| C | 0.45 | | 0.60 | 0.018 | | 0.024 |
| C2 | 1.25 | | 1.35 | 0.049 | | 0.053 |
| C3 | 2.20 | | 2.60 | 0.087 | | 0.102 |
| D | 8.90 | | 9.90 | 0.350 | | 0.390 |
| E | 9.90 | | 10.30 | 0.390 | | 0.406 |
| E1 | 0.80 | | 1.20 | 0.031 | | 0.047 |
| F | 6.30 | | 6.90 | 0.248 | | 0.272 |
| G | 2.40 | | 2.70 | 0.094 | | 0.106 |
| H | 28.00 | | 29.80 | 1.102 | | 1.173 |
| H1 | 2.15 | | 2.55 | 0.085 | | 0.100 |
| I | 4.70 | | 5.10 | 0.185 | | 0.201 |
| K | 9.90 | | 10.30 | 0.390 | | 0.406 |
| L1 | 2.70 | | 3.30 | 0.106 | | 0.130 |
| L2 | 1.14 | | 1.70 | 0.045 | | 0.067 |
| L3 | 2.65 | | 2.95 | 0.104 | | 0.116 |
| M | 4.80 | | 5.20 | 0.189 | | 0.205 |

DELIVERY MODE



| PACKAGE | OUTLINE | TUBE (PCS) | INNER BOX (PCS) | PER CARTON |
|---------|---------|------------|-----------------|------------|
| TO-220C | TUBE | 50 | 1,000 | 5,000 |