

## DESCRIPTION:

With high ability to withstand the shock loading of large current, SCT1655Z SCR provides high  $dV/dt$  rate with strong resistance to electromagnetic interference. It is especially recommended for use on solid state relay, motorcycle, SVC, power charger, T-tools etc. From all three terminals to external heatsink, SCT1655Z provides a rated insulation voltage of 2500  $V_{RMS}$ , complying with UL standards (File ref: E252906). Package TO-3P is RoHS compliant.

## MAIN FEATURES

Symbol	Value	Unit
$I_{T(RMS)}$	55	A
$V_{DRM}/V_{RRM}$	1600	V
$I_{GT}$	10-80	mA

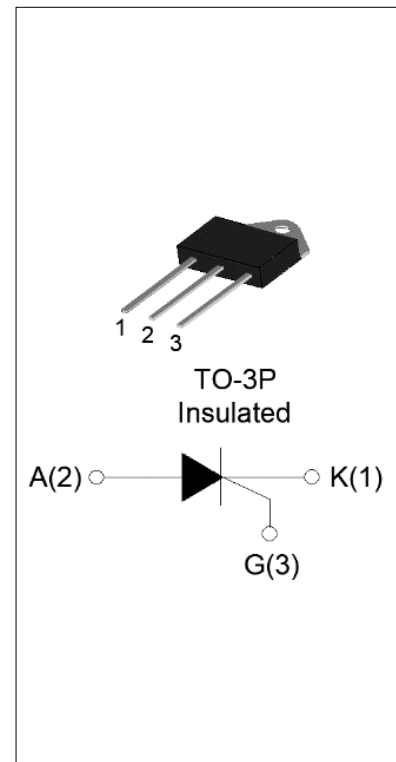

## ABSOLUTE MAXIMUM RATINGS

Parameter	Symbol	Value	Unit
Storage junction temperature range	$T_{stg}$	-40-150	$^{\circ}C$
Operating junction temperature range	$T_j$	-40-125	$^{\circ}C$
Repetitive peak off-state voltage ( $T_j=25^{\circ}C$ )	$V_{DRM}$	1600	V
Repetitive peak reverse voltage ( $T_j=25^{\circ}C$ )	$V_{RRM}$	1600	V
Average on-state current ( $T_c \leq 70^{\circ}C$ )	$I_{T(AV)}$	35	A
RMS on-state current ( $T_c \leq 70^{\circ}C$ )	$I_{T(RMS)}$	55	A
Non repetitive surge peak on-state current ( $t_p=10ms, T_j=25^{\circ}C$ )	$I_{TSM}$	600	A
Non repetitive surge peak on-state current ( $t_p=8.3ms, T_j=25^{\circ}C$ )		640	
$I^2t$ value for fusing ( $t_p=10ms, T_j=25^{\circ}C$ )		1800	$A^2s$
Critical rate of rise of on-state current ( $I_G=2 \times I_{GT}, f=100Hz, T_j=125^{\circ}C$ )	$di/dt$	200	$A/\mu s$

Peak gate current ( $t_p=20\mu s$ , $T_j=125^\circ C$ )	$I_{GM}$	12	A
Average gate power dissipation ( $T_j=125^\circ C$ )	$P_{G(AV)}$	1	W
Peak gate power	$P_{GM}$	22	W
Peak pulse voltage ( $T_j=25^\circ C$ ; non-repetitive, off-state; FIG.7)	$V_{pp}$	1.2	kV

**ELECTRICAL CHARACTERISTICS** ( $T_j=25^\circ C$  unless otherwise specified)

Symbol	Test Condition	Value			Unit
		MIN.	TYP.	MAX.	
$I_{GT}$	$V_D=12V$ $R_L=33\Omega$	10	-	80	mA
$V_{GT}$		-	-	1.3	V
$V_{GD}$	$V_D=V_{DRM}$ $T_j=125^\circ C$ $R_L=3.3k\Omega$	0.25	-	-	V
$I_L$	$I_G=1.2I_{GT}$	-	-	250	mA
$I_H$	$I_T=500mA$	-	-	200	mA
dV/dt	$V_D=1070V$ Gate Open $T_j=125^\circ C$	2200	-	-	V/ $\mu s$
$t_{on}$	$I_G=100mA$ $I_A=1A$ $I_R=100mA$ $T_j=25^\circ C$	-	10	-	$\mu s$
$t_{off}$		-	150	-	

**STATIC CHARACTERISTICS**

Symbol	Parameter		Value(MAX.)	Unit
$V_{TM}$	$I_{TM}=80A$ $t_p=380\mu s$	$T_j=25^\circ C$	1.7	V
$V_{TO}$	Threshold voltage	$T_j=125^\circ C$	0.89	V
$R_D$	Dynamic resistance	$T_j=125^\circ C$	8.7	m $\Omega$
$I_{DRM}$	$V_D=V_{DRM}$ $V_R=V_{RRM}$	$T_j=25^\circ C$	20	$\mu A$
$I_{RRM}$		$T_j=125^\circ C$	8	mA

**THERMAL RESISTANCES**

Symbol	Parameter	Value	Unit
$R_{th(j-c)}$	junction to case (DC)	0.65	$^\circ C/W$
$R_{th(j-a)}$	junction to ambient (DC)	50	$^\circ C/W$

## ORDERING INFORMATION

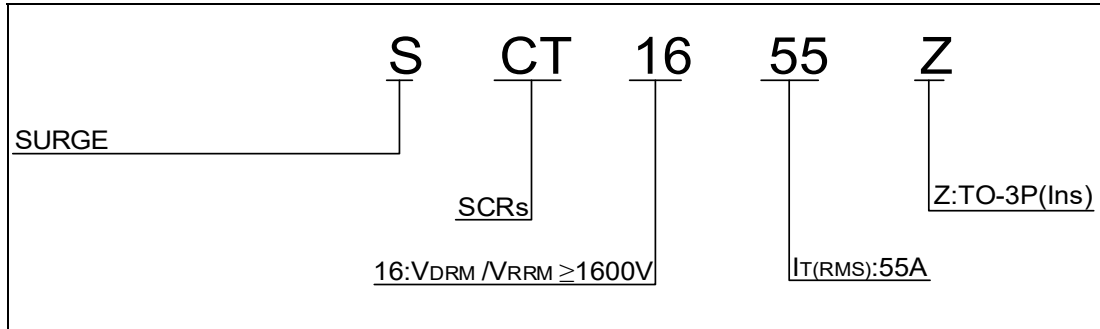

## MARKING

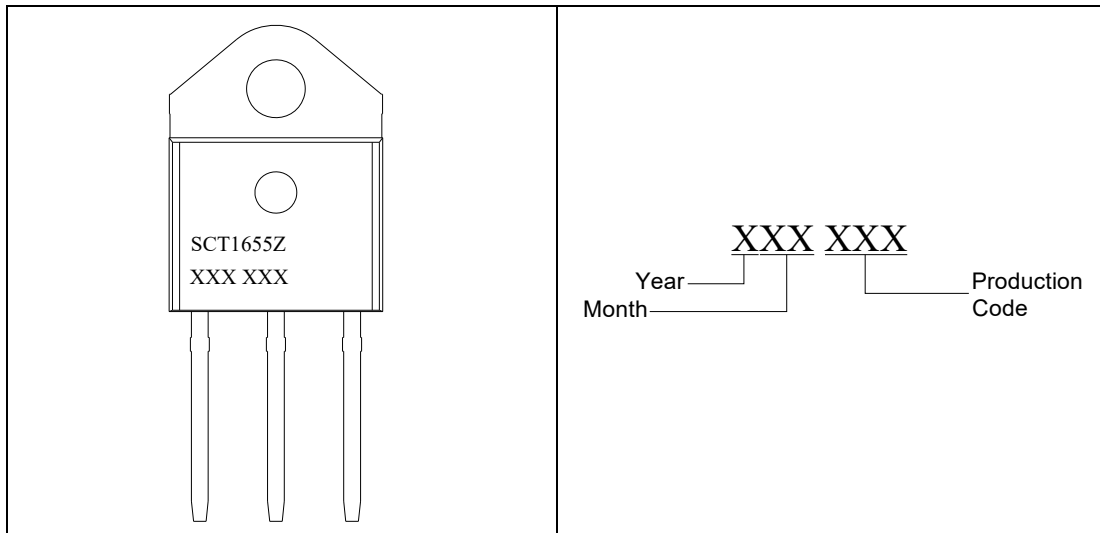

**FIG.1:** Maximum power dissipation versus RMS on-state current

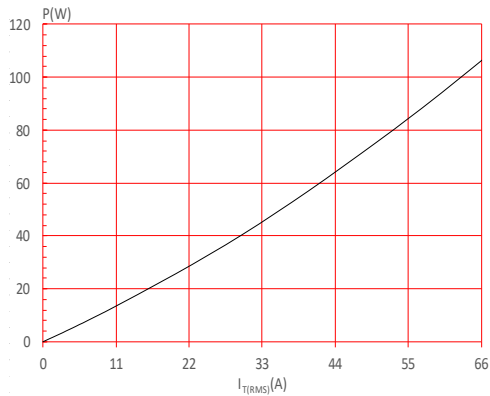

**FIG.2:** RMS on-state current versus case temperature

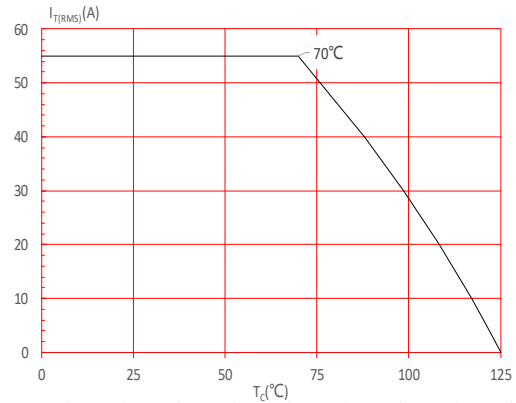

**FIG.3:** Surge peak on-state current versus number of cycles

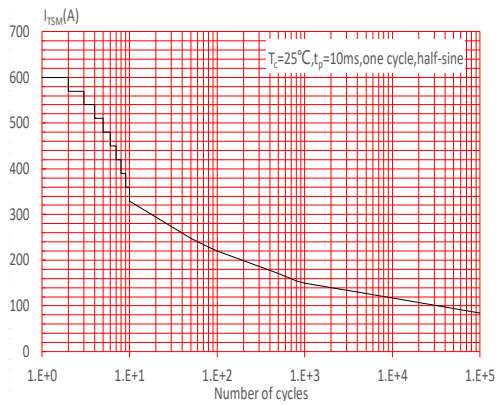

**FIG.4:** On-state characteristics

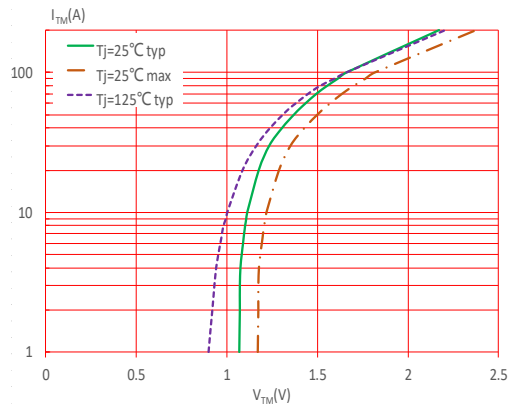

**FIG.5:** Non-repetitive surge peak on-state current for a sinusoidal pulse with width  $t_p < 10\text{ms}$ , and corresponding value of  $I^2t$  ( $di/dt < 200\text{A}/\mu\text{s}$ )

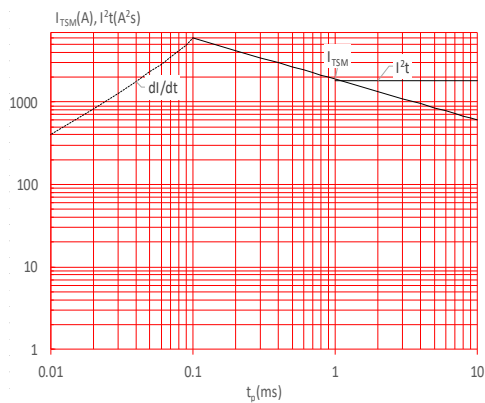

**FIG.6:** Relative variations of gate trigger current, holding current and latching current versus junction temperature

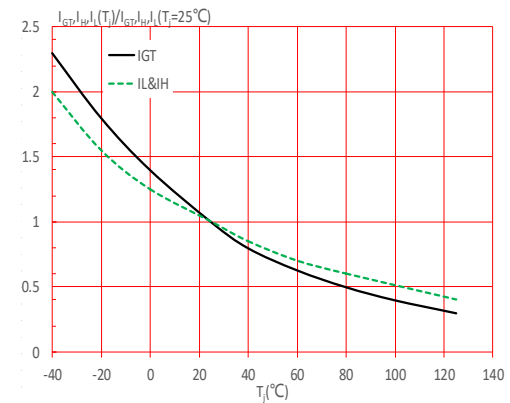
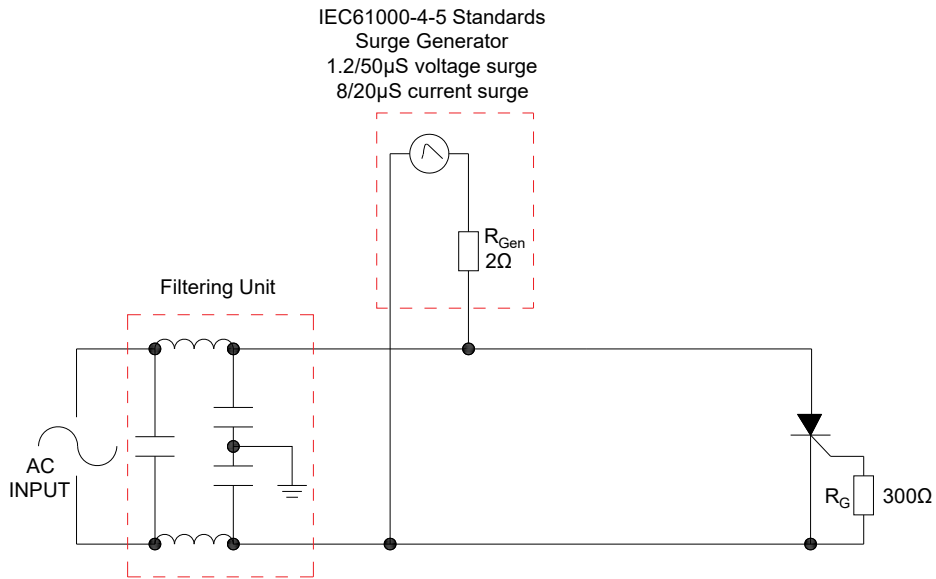

FIG.7: Test circuit for inductive and resistive loads to IEC-61000-4-5 standards.



## LEAD FORMING AND SOLDERING

Refer to the application note “Assembly Instructions for Thyristors in Through-hole Package”

**ORDERING INFORMATION**

Order code	Voltage $V_{DRM}/V_{RRM}$ (V)	IGT(mA)	Package	Base qty. (pcs)	Delivery mode
SCT1655Z	1600	10-80	TO-3P(Ins)	30	Tube

**Document Revision History**

Date	Revision	Changes
Apr.13, 2023	A.1.0	Last update
Oct.16, 2025	A.1.1	Revise PACKAGE MECHANICAL DATA

## PACKAGE MECHANICAL DATA

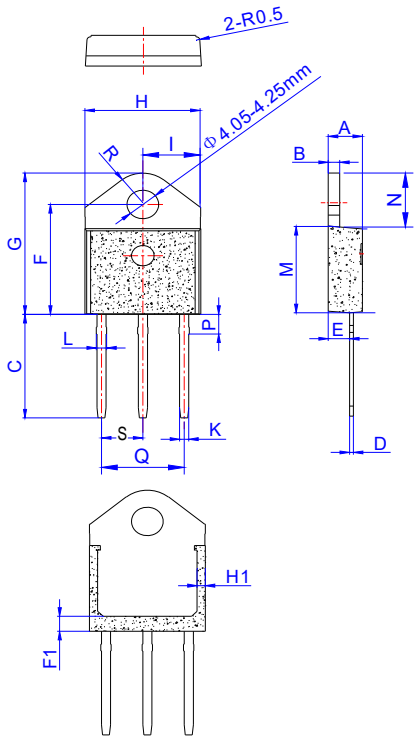

Ref.	Dimensions					
	Millimeters			Inches		
	Min.	Typ.	Max.	Min.	Typ.	Max.
A	4.40		4.60	0.173		0.181
B	1.45		1.55	0.057		0.061
C	14.35		15.60	0.565		0.614
D	0.50		0.70	0.020		0.028
E	2.70		2.90	0.106		0.114
F	15.80		16.50	0.622		0.650
F1	2.45		2.85	0.096		0.112
G	20.40		21.10	0.803		0.831
H	15.10		15.50	0.594		0.610
H1	1.10		1.50	0.043		0.059
I	7.25		7.65	0.285		0.301
S	5.40		5.65	0.213		0.222
K	1.10		1.40	0.043		0.055
L	1.25		1.45	0.049		0.057
M	12.37		12.77	0.487		0.503
N	7.80		8.20	0.307		0.323
P	2.80		3.00	0.110		0.118
Q	10.70		11.10	0.421		0.437
R		4.35			0.171	

## DELIVERY MODE

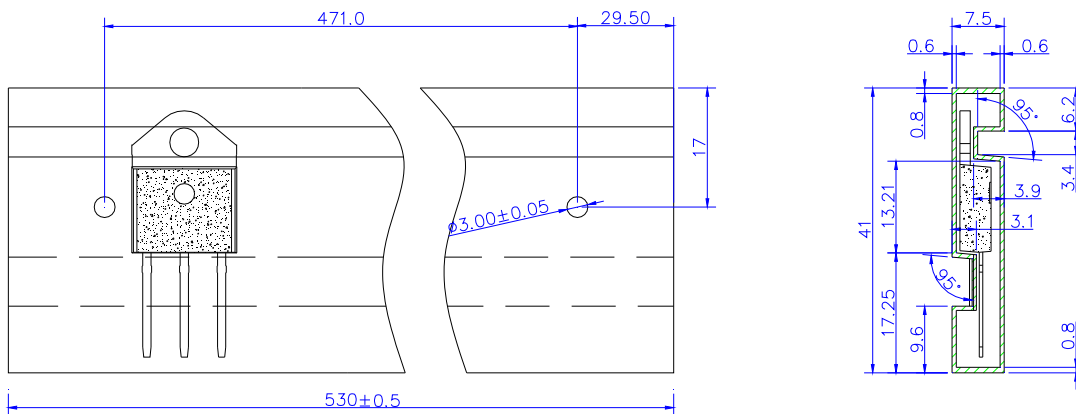

PACKAGE	OUTLINE	TUBE (PCS)	INNER BOX (PCS)	PER CARTON
TO-3P	TUBE	30	450	2,250

Information furnished in this document is believed to be accurate and reliable. However, Surge Components assumes no responsibility for the consequences of use without consideration for such information nor use beyond it. Information mentioned in this document is subject to change without notice.

Products and information provided in this document have no infringement of patents. Surge Components assumes no responsibility for any infringement of other rights of third parties which may result from the use of such products and information. This document supersedes and replaces all information previously supplied.