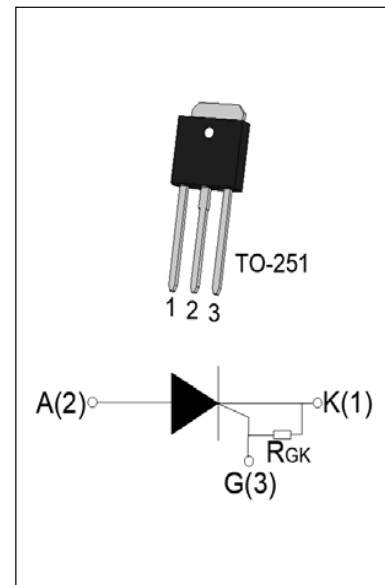


DESCRIPTION:

The SR0405H SCR with the parallel resistor between Gate and Cathode, $R_{GK}=10\sim 80k\Omega$, is especially recommended for use on straight hair, igniter, anion generator, etc. Package TO-251 is RoHS compliant.

MAIN FEATURES

Symbol	Value	Unit
$I_{T(RMS)}$	4	A
V_{DRM}/V_{RRM}	600	V
I_{GT}	≤ 200	μA


ABSOLUTE MAXIMUM RATINGS

Parameter	Symbol	Value	Unit
Storage junction temperature range	T_{stg}	-40-150	$^{\circ}C$
Operating junction temperature range	T_j	-40-125 ^①	$^{\circ}C$
Repetitive peak off-state voltage ($T_j=25^{\circ}C$)	V_{DRM}	600	V
Repetitive peak reverse voltage ($T_j=25^{\circ}C$)	V_{RRM}	600	V
Average on-state current ($T_c \leq 93^{\circ}C$)	$I_{T(AV)}$	2.5	A
RMS on-state current ($T_c \leq 93^{\circ}C$)	$I_{T(RMS)}$	4	A
Non repetitive surge peak on-state current ($t_p=10ms, T_j=25^{\circ}C$)	I_{TSM}	40	A
Non repetitive surge peak on-state current ($t_p=8.3ms, T_j=25^{\circ}C$)		44	
I^2t value for fusing ($t_p=10ms, T_j=25^{\circ}C$)	I^2t	8	A^2s
Critical rate of rise of on-state current ($I_G=2 \times I_{GT}, f=100Hz, T_j=125^{\circ}C$)	di/dt	50	$A/\mu s$
Peak gate current ($t_p=20\mu s, T_j=125^{\circ}C$)	I_{GM}	2	A
Average gate power dissipation ($T_j=125^{\circ}C$)	$P_{G(AV)}$	0.5	W

Peak gate power	P_{GM}	5	W
Peak pulse voltage ($T_j=25^\circ\text{C}$; non-repetitive, off-state; FIG.7)	V_{pp}	0.5	kV

NOTE 1: Operating junction temperature T_j is up to 125°C when a resistor $\leq 1\text{k}\Omega$ is connected between Gate and Cathode. Without this resistor, the T_j is up to 110°C only.

ELECTRICAL CHARACTERISTICS ($T_j=25^\circ\text{C}$ unless otherwise specified)

Symbol	Test Condition	Value			Unit
		MIN.	TYP.	MAX.	
I_{GT}	$V_D=12\text{V}$ $R_L=33\Omega$	-	50	200	μA
V_{GT}		-	0.6	0.8	V
V_{GD}	$V_D=V_{DRM}$ $T_j=125^\circ\text{C}$	0.2	-	-	V
I_L	$I_G=1.2 I_{GT}$	-	-	6	mA
I_H	$I_T=0.1\text{A}$	-	-	5	mA
dV/dt	$V_D=400\text{V}$ $T_j=125^\circ\text{C}$ $R_{GK}=1\text{k}\Omega$	50	-	-	V/ μs
	$V_D=400\text{V}$ $T_j=125^\circ\text{C}$ $R_{GK}=220\Omega$	250	-	-	
t_{on}	$I_G=10\text{mA}$ $I_A=20\text{mA}$ $I_R=2\text{mA}$ $T_j=25^\circ\text{C}$	-	2	-	μs
t_{off}		-	50	-	

STATIC CHARACTERISTICS

Symbol	Parameter		Value(MAX.)	Unit
V_{TM}	$I_{TM}=8\text{A}$ $t_p=380\mu\text{s}$	$T_j=25^\circ\text{C}$	1.6	V
V_{TO}	Threshold voltage	$T_j=125^\circ\text{C}$	0.64	V
R_D	Dynamic resistance	$T_j=125^\circ\text{C}$	0.08	Ω
I_{DRM}	$V_D=V_{DRM}$ $V_R=V_{RRM}$	$T_j=25^\circ\text{C}$	5	μA
I_{RRM}		$T_j=125^\circ\text{C}$	0.5	mA

THERMAL RESISTANCES

Symbol	Parameter	Value	Unit
$R_{th(j-c)}$	junction to case (DC)	6	$^\circ\text{C}/\text{W}$
$R_{th(j-a)}$	junction to ambient (DC)	120	$^\circ\text{C}/\text{W}$

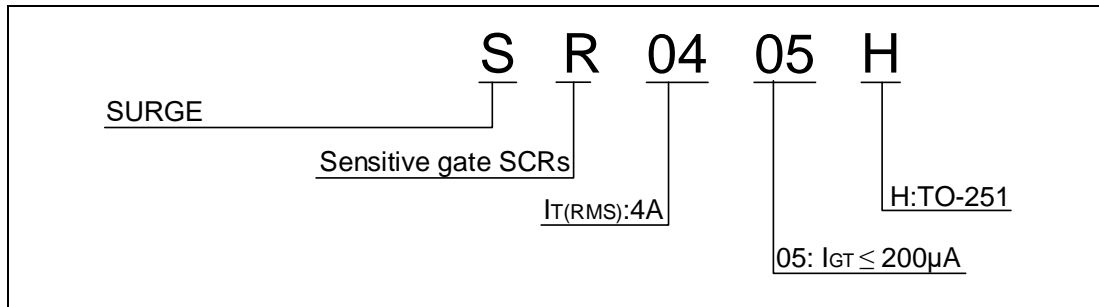
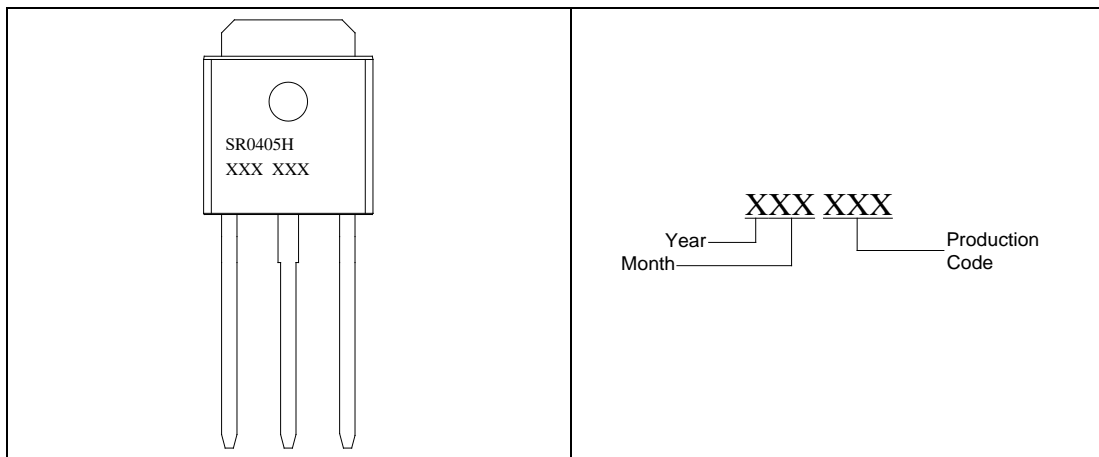
ORDERING INFORMATION

MARKING


FIG.1: Maximum power dissipation versus RMS on-state current

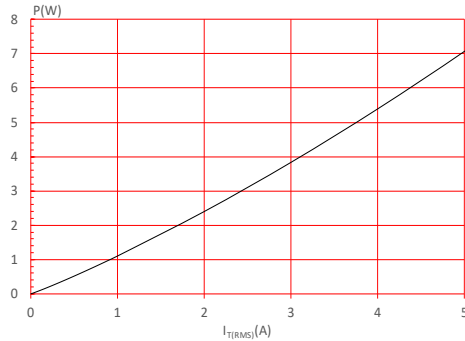


FIG.2: RMS on-state current versus case temperature

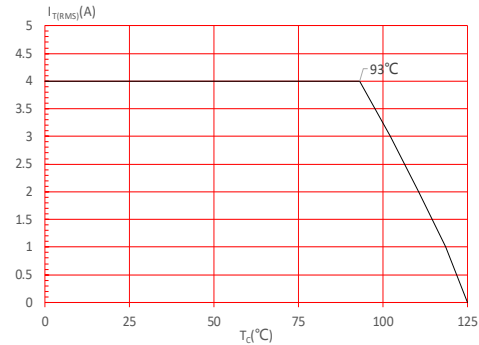


FIG.3: Surge peak on-state current versus number of cycles

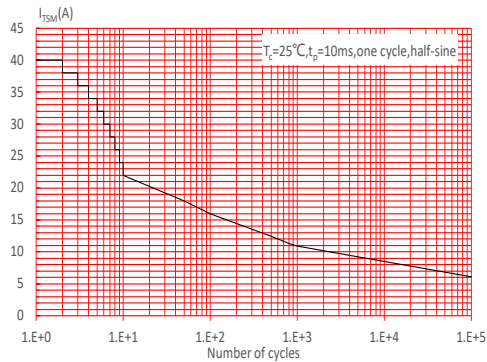


FIG.4: On-state characteristics

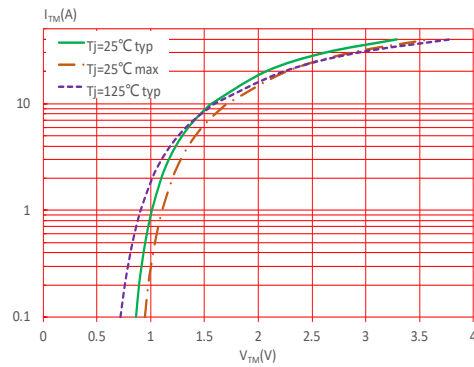


FIG.5: Non-repetitive surge peak on-state current for a sinusoidal pulse with width $t_p < 10\text{ms}$, and corresponding value of I^2t ($di/dt < 50\text{A}/\mu\text{s}$)

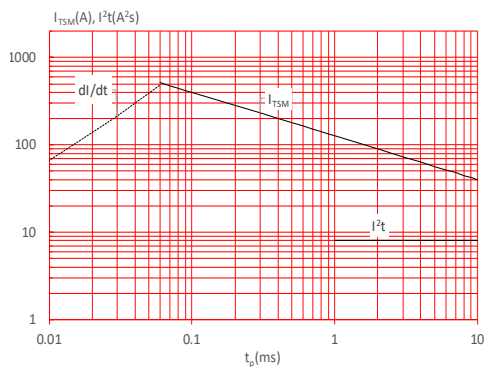


FIG.6: Relative variations of gate trigger current, holding current and latching current versus junction temperature

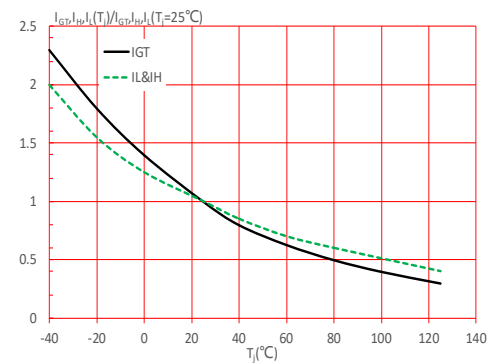
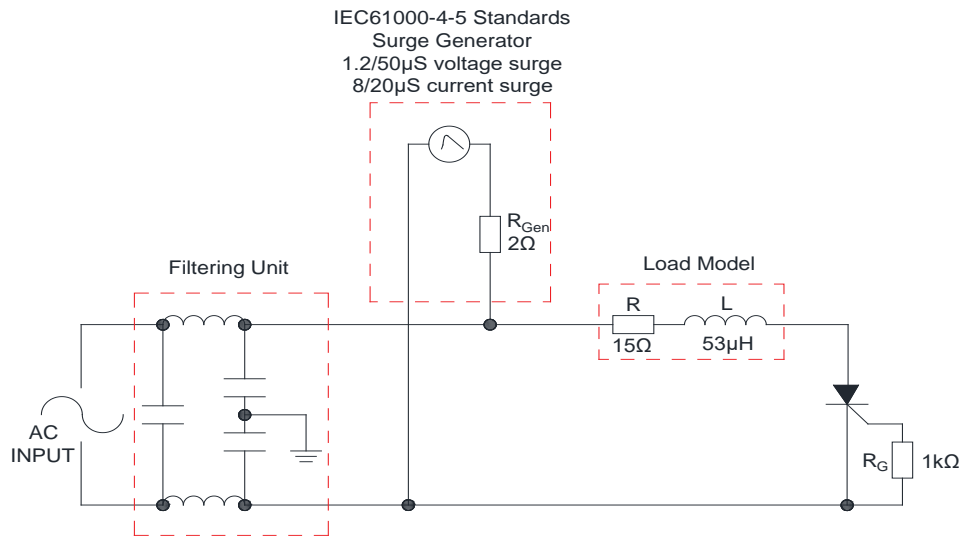


FIG.7: Test circuit for inductive and resistive loads to IEC-61000-4-5 standards



LEAD FORMING AND SOLDERING

Refer to the application note “Assembly Instructions for Thyristors in Through-hole Package”

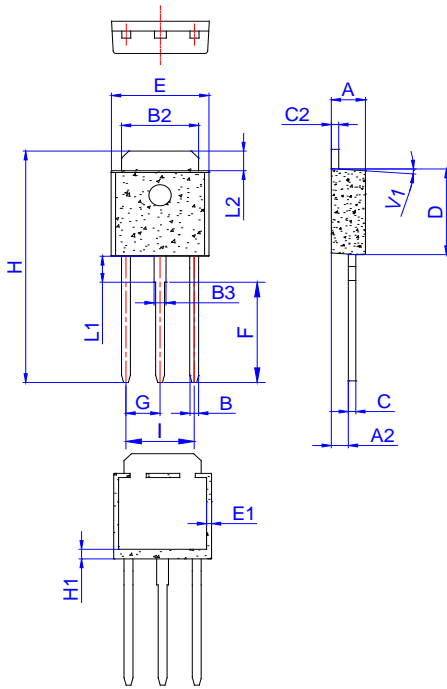
ORDERING INFORMATION

Order code	Voltage V_{DRM}/V_{RRM} (V)	IGT(μ A)	Package	Base qty. (pcs)	Delivery mode
SR0405H	600	≤ 200	TO-251	80	Tube

Document Revision History

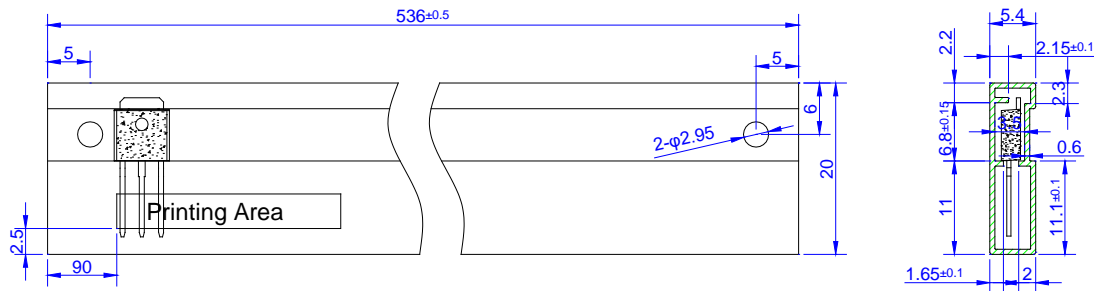
Date	Revision	Changes
Apr.10, 2023	A.1.0	Last update
Oct.16, 2025	A.1.1	Revise PACKAGE MECHANICAL DATA

PACKAGE MECHANICAL DATA



Ref.	Dimensions					
	Millimeters			Inches		
	Min.	Typ.	Max.	Min.	Typ.	Max.
A	2.20		2.40	0.086		0.095
A2	1.00		1.30	0.039		0.051
B	0.50		0.70	0.020		0.028
B2	5.10		5.40	0.200		0.213
B3	0.70		1.00	0.028		0.039
C	0.45		0.62	0.018		0.024
C2	0.48		0.62	0.019		0.024
D	6.00		6.20	0.236		0.244
E	6.40		6.70	0.252		0.264
E1	0.60		1.00	0.024		0.039
F	6.90		7.30	0.272		0.287
G	2.20		2.40	0.087		0.094
H	16.00		17.00	0.630		0.669
H1	1.45		1.85	0.057		0.073
I	4.40		4.80	0.173		0.189
L1	1.80		2.20	0.071		0.087
L2	1.25		1.55	0.049		0.061
V1		4°			4°	

DELIVERY MODE



PACKAGE	OUTLINE	TUBE (PCS)	INNER BOX (PCS)	PER CARTON
TO-251	TUBE	80	4,000	20,000

Information furnished in this document is believed to be accurate and reliable. However, Surge Components assumes no responsibility for the consequences of use without consideration for such information nor use beyond it. Information mentioned in this document is subject to change without notice.

Products and information provided in this document have no infringement of patents. Surge Components assumes no responsibility for any infringement of other rights of third parties which may result from the use of such products and information. This document supersedes and replaces all information previously supplied.